

# ***Power Stage Thermal Design for DDX Amplifiers***

For Applications Assistance Contact:  
Apogee Technical Support  
e-mail: [support@apogeeddx.com](mailto:support@apogeeddx.com)

## Table of Contents

1.	ABSTRACT .....	3
2.	INTRODUCTION.....	4
3.	BACKGROUND .....	4
3.1.	Thermal Impedance.....	4
3.2.	Thermal Capacitance.....	4
3.3.	Thermal Resistance of a Flat Plate.....	5
3.4.	Thermal Time Constant.....	5
3.5.	Spreading Resistance.....	5
4.	Thermal Design of the PC Board.....	6
5.	Other Thermal Considerations.....	9
6.	Conclusions.....	10
	Appendix A. Properties of Certain Materials.....	11
	Appendix B. What About Using Thinner Copper Foils? .....	12
	Appendix C. Effects of Device Positioning on the Board.....	14

## Table of Figures

Figure 1.	Simplified Thermal Impedance Model of a PowerSO Soldered to a PC Board Using Vias.....	6
Figure 2.	Typical PowerSO PC Board Mounting.....	6
Figure 3.	Recommended Solder Mask and Layout of Vias.....	7
Figure 4.	Temperature Rise vs. Thermal Time Constant .....	8
Figure 5.	PowerSO With One or Two AAVID #573400 Heat Sinks.....	9
Figure 6.	Thermal gradients of a PowerSO on a 5 in. x5 in. two-sided board vs. copper foil thickness. ...	12
Figure 7.	Top Foil Pattern for Model.....	12
Figure 8.	Thermal Gradients of Some 5 in. x 5 in. Materials .....	13
Figure 9.	Positioning the PowerSO.....	14
Figure 10.	Heat Rise Of Two PowerSOs Placed One Inch Apart.....	14

## List of Tables

Table 1.	Similarity of Thermal calculations to Electrical Calculations .....	4
Table 2.	Test Results of EB-2060S Output Power vs. Heatsink Method.....	9
Table 3.	Properties of Certain Materials .....	11

## **1. ABSTRACT**

In general, low power semiconductors are designed with enough surface area to dissipate their internal power into free air and maintain the silicon die at a safe operating temperature. Power ICs, however, carry large amounts of power and dissipate much more than their packages alone will allow. They require some kind of a heatsink to dissipate the excess power. Without some form of heatsink they would quickly overheat, leading to either device failure or thermal shutdown. Since there are few “thermal cookbooks” for simple solutions to heat-sinking high power SMD packages we will discuss methods of dissipating that heat.

## 2. INTRODUCTION

It is necessary to consider the thermal effects of power dissipation when designing with any Power IC. In this paper we will use the DDX-2060 power IC that is in a PowerSO-36 package. The calculations and figures presented can apply to almost any IC with a heat spreader that can be soldered down, including D<sup>3</sup>PAKs and the like. Since all of the heat dissipated in the power IC has to end up in the room air we will show how to get it there. We also discuss the relative merits and weaknesses of several heat sinking methods.

## 3. BACKGROUND

Before we can discuss particular heat sinking methods we need to understand some basic concepts of heat flow. The methods of calculating heat flow are very similar to those for calculating electrical current flow. A thermal system can be modeled in much the same way as an electrical system. This allows us to use variations of familiar formulas such as Ohm's law and Kirchoff's laws to arrive at an approximate solution to a particular heat problem. (Exact mathematical solutions, requiring the use of partial differential equations and or finite element modeling, are beyond the scope of this paper.) The following table shows the analogy between thermal heat flow and electrical current flow:

Quantity	Thermal System	Thermal Units	Electrical System	Electrical Units
Potential	T	°C	E	V
Flow	q	Watts (or J/s)	I	Coulomb/s
Resistance	R <sub>θ</sub>	°C/Watt	R	Ohm
Conductance	G	W/°C	1/R	Mho
Capacitance	C <sub>TH</sub>	J/°C	C	Farad
Ohm's Law	T=q* R <sub>θ</sub>	---	E=I*R	---

Table 1. Similarity of Thermal calculations to Electrical Calculations

### 3.1. Thermal Impedance.

Thermal Impedance is similar to electrical impedance and consists of the following:

- Thermal Resistance** (why the chip can't get rid of its heat)
- Thermal Capacitance** (short bursts of heat stored locally and dissipated later)
- Thermal Inductance** (effect of thermal inductance are usually very small.)

From the above table we see that **Thermal resistance** is to the flow of heat as electrical resistance is to the flow of current. This means that, over time, a certain amount of continuous power put into a semiconductor will raise its temperature in direct proportion to the total thermal resistance of all paths that dissipate it. The equation for heat flow, similar to Ohm's law, is:

$$T = q * R_{\theta} \tag{Equation 1}$$

where:

- T = Temperature potential across the thermal resistance (°C)
- q = Heat flow through the thermal resistance (Watts)
- R<sub>θ</sub> = Thermal resistance (°C/Watt)

### 3.2. Thermal Capacitance.

Thermal Capacitance is to thermal energy as an electrical capacitor is to an electric charge. It is the amount of energy required to raise a specific mass with a specific heat by 1 °C. The equation for thermal capacitance is:

$$C_{TH} = v * \rho * C_i \tag{Equation 2}$$

where:

- $C_{TH}$  = Thermal Capacitance, J/°C
- $v$  = Volume, m<sup>3</sup>
- $\rho$  = Density, kg/m<sup>3</sup>
- $C_t$  = Specific Heat, J/(kg-°C)

It is fairly simple to compute the thermal capacity of an object if we know it's material composition and physical dimensions. Appendix A lists these values for some common materials used in electronic design.

### 3.3. Thermal Resistance of a Flat Plate.

A good first-order approximation ( $\pm 10\%$ ) for calculating the thermal resistance of a flat plate (where spreading resistance is not a major factor) is:

$$R_{\theta} = 80 * A^{-0.7} * P^{-0.15}$$

*Equation 3*

where:

- $R_{\theta}$  = Thermal Resistance, in °C/Watt
- $P$  = Power, in Watts
- $A$  = Area, in square inches (including both sides)

### 3.4. Thermal Time Constant.

The product of the thermal resistance and thermal capacitance, is defined as:

$$\tau_{TH} = R_{\theta} * C_{TH}$$

*Equation 4*

It's important to know the thermal time constant for each component of your thermal design. Parts with very short thermal time constants will resolve to just their steady-state thermal resistance when used with other long thermal time constant components. The packaged semiconductor alone has an extremely short time constant, but this is usually sufficient to handle thermal transients that occur at the switching frequency. The time constant of the PowerSO will be short compared to the PC board's time constant so that the PC board's time constant will dominate and the IC's thermal impedance will appear as just a thermal resistance. Medium time constants, such as the time constant of the PowerSO plus the heat sink provided by the PC board's copper foil are capable of handling transients due to audio program content but become limited for long term, steady state RMS power handling. To handle near-continuous thermal needs a large mass heat sink with a medium dissipation area, or a large heat sink surface area with a smaller thermal mass may be used.

### 3.5. Spreading Resistance

Spreading Resistance, or lateral resistance to heat flow, becomes a major factor in cooling semi-conductors with just the PC board' copper foil since it is usually very thin with respect to the distance along the surface.

Figure 1 shows the circuit complexity of a PowerSO package soldered to a double-sided printed wiring board. Each resistance has a capacitance associated with it and has its own thermal time constant. From this diagram we see that heat flow through the copper foil decreases with distance, causing radiation to the air (and also the temperature) to decrease severely with distance from the source.

**For two-ounce copper this effectively limits the heat sinking to a 2½-inch diameter circle.**

**For one-ounce copper this effectively limits the heat sinking to less than a 2-inch diameter circle.**

For a further discussion of spreading resistance and copper thickness effects see Appendix B.

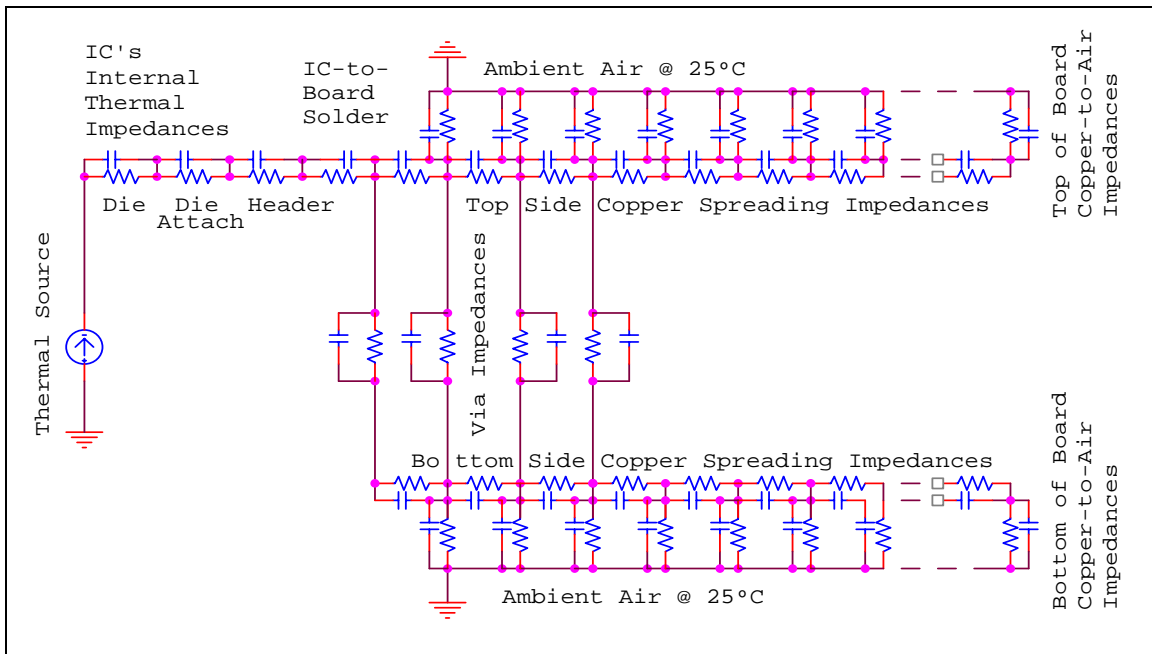

Figure 1. Simplified Thermal Impedance Model of a PowerSO Soldered to a PC Board Using Vias.

#### 4. Thermal Design of the PC Board

Figure 2 shows the **recommended layout** for the Power SO package mounted on a double-sided PC board and connected through with thermal vias. The total thermal resistance of the paralleled vias must be much lower than the thermal resistance of the board surface area. A copper-clad board alone is not as good for dissipating heat as your typical aluminum heat sink because it has a much smaller thermal mass.

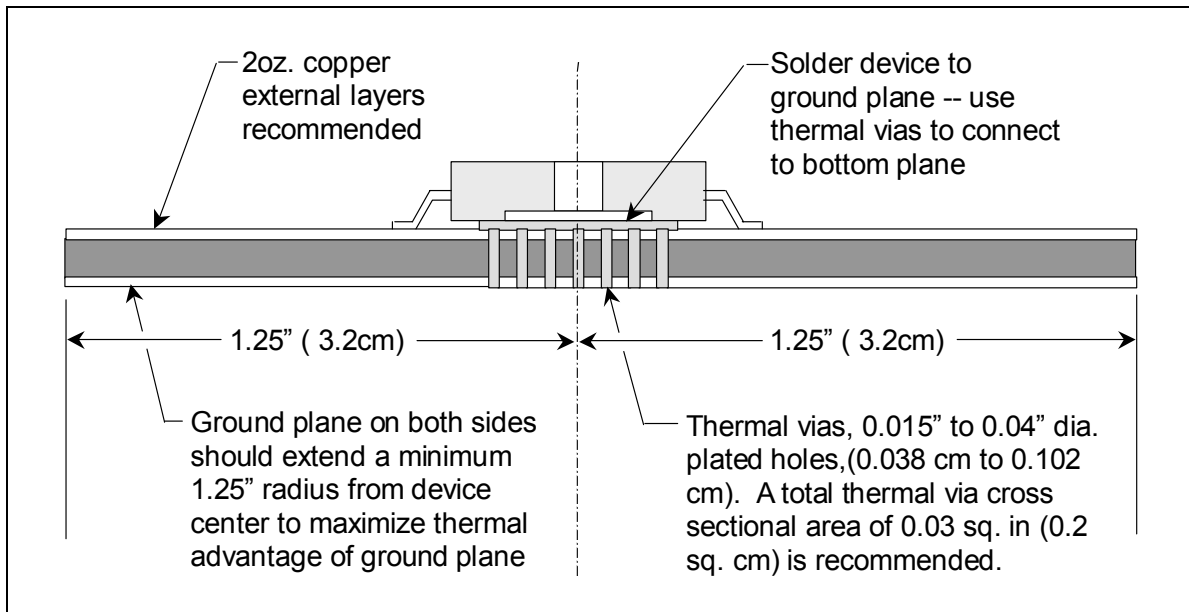

Figure 2. Typical PowerSO PC Board Mounting.

As an example, a DDX-2060 delivering 50 watts of power to the load, at 86% efficiency, mounted on a two-ounce double-sided board will have an internal dissipation of:

$$P_{out}/\eta - P_{out} = 50/0.86 - 50 \approx 8W \quad \text{Equation 5}$$

Using Equation 3 we then calculate the thermal resistance using the total effective area of 10 square inches (assuming no losses in the vias) at this power level of 8 watts. This results in a thermal resistance of 11.7 °C/W from sink-to-air. If we then add the 2.5 °C/W for the DDX-2060 package we get 14.2 °C/W total, which yields a temperature rise of 113°C above ambient or 138°C total at the semiconductor junction for a 25°C ambient. Actual measurements on the EB-2060S Demo Board match these calculations within 5%.

A DDX-2060 PowerSO, powered at 28 VDC and controlled with a DDX-2000 or DDX-4100 controller can produce up to 35W output per channel at less than 1% THD+N for a total power output of 70W. If we repeat the calculations at this increased power level we get the following total on-board dissipation:

$$P_{out}/\eta - P_{out} = 70 / 0.86 - 70 = 11.4W \quad \text{Equation 6}$$

The thermal resistance at this higher power is slightly lower than it was at the lower power:

$$R_{\theta s-a} = 11.1 \text{ } ^\circ\text{C/W} \quad \text{Equation 7}$$

which leads us to:

$$R_{\theta j-a} = 13.6 \text{ } ^\circ\text{C/W} \quad \text{Equation 8}$$

$$T_j = 180 \text{ } ^\circ\text{C} \quad \text{Equation 9}$$

This places it well above the IC's 150°C rating. The DDX-2060's protective thermal shutdown would become active if we left it running continuously at this power level.

Thermal capacitance helps us here. We first calculate the steady-state thermal rise across the power IC:

$$T_{j-c} = 11.4W * 2.5 \text{ } ^\circ\text{C/W} = 28.5 \text{ } ^\circ\text{C} \quad \text{Equation 10}$$

Subtracting both  $T_{j-c}$  and the ambient temperature from 150 °C we get:

$$T_{s-a}(\text{allowed}) = 150 \text{ } ^\circ\text{C} - 28.5 \text{ } ^\circ\text{C} - 25 \text{ } ^\circ\text{C} = 96.5 \text{ } ^\circ\text{C} \quad \text{Equation 11}$$

This is the maximum  $T_{s-a}$  that is allowed. If we apply the power for only a brief time and then allow time to cool we can work with the thermal time constant to keep the IC's junction temperature within safe limits. Figure 4 shows a temperature rise vs. time constant curve that we can use to "overdrive" the Power IC for short periods and still stay within the safe operating area.

The maximum sink-to-air temperature rise, due to the 11.4 W dissipation in the heat sink, is

$$T_{s-a}(\text{max.}) = 11.4W * 11.1 \text{ } ^\circ\text{C/W} = 126.5 \text{ } ^\circ\text{C} \quad \text{Equation 12}$$

The allowable temperature rise from Equation 11 is 96.5 °C. Hence the percentage of allowable power vs. maximum power is:

$$96.5 \text{ } ^\circ\text{C} / 126.5 \text{ } ^\circ\text{C} = 76\% \quad \text{Equation 13}$$

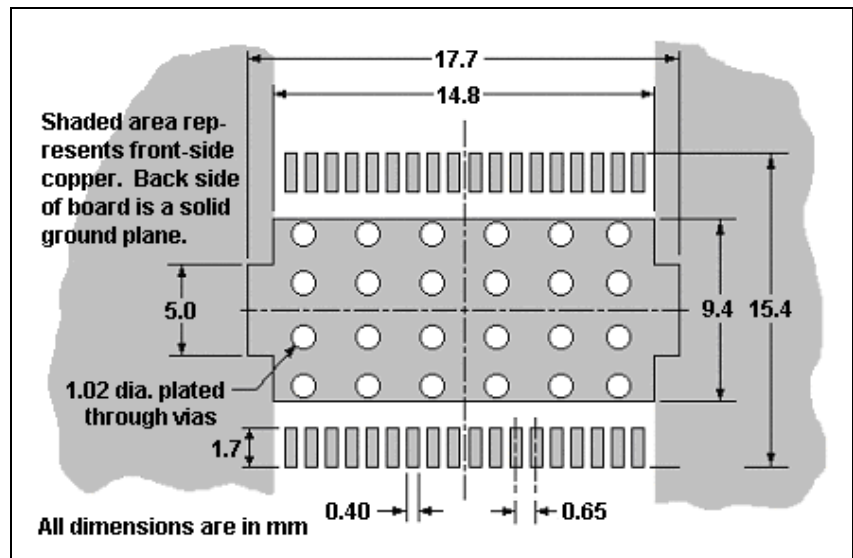

**Figure 3. Recommended Solder Mask and Layout of Vias.**

Find this point on the curve in Figure 4, which corresponds to about 1.5 time constants. Lets see how long we can operate at this (maximum) power with the given design. For this particular case, the mass of the thermal vias will be ignored. Referring back to values in Table 1 we find that the total thermal capacitance, including both sides of the PC board is:

$$C_{foil} = 10 \text{ in.}^2 * 0.0028 \text{ in.} * (16.4 \times 10^{-9} \text{ m}^3 / \text{in.}^3) * 8960 \text{ kg/m}^3 * 385 \text{ J/(kg}^\circ\text{C)} = 0.0016 \text{ J}^\circ\text{C} \quad \text{Equation 14}$$

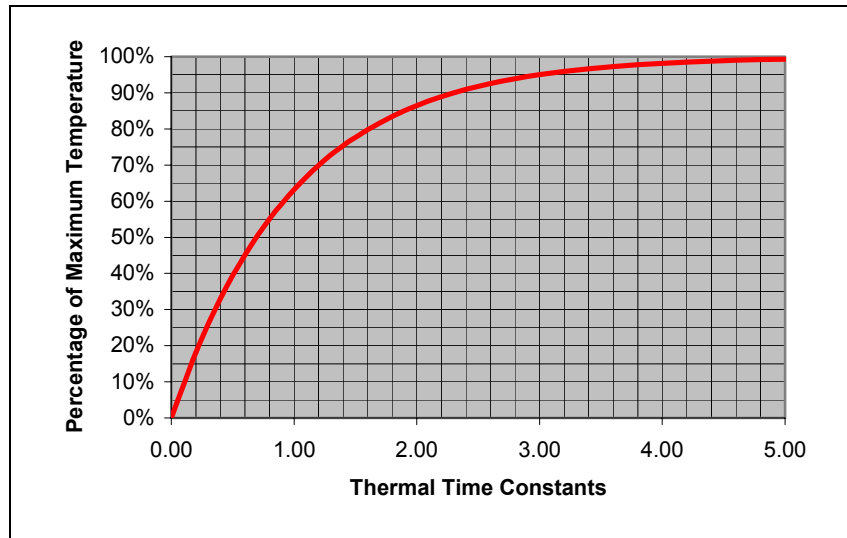

**Figure 4. Temperature Rise vs. Thermal Time Constant**

While the glass epoxy part of the PC board does virtually nothing to dissipate or spread the heat, it does add to the total thermal capacitance, so we'll calculate and add in the epoxy board's thermal capacitance

$$C_{glass-epoxy} = 0.25 \text{ in.}^3 * (16.4 \times 10^{-9} \text{ m}^3 / \text{in.}^3) * 1200 \text{ kg/m}^3 * 1750 \text{ J/(kg}^\circ\text{C)} * = 0.0086 \text{ J}^\circ\text{C} \quad \text{Equation 15}$$

And also the thermal capacitance for the IC's body and heat spreader:

$$C_{IC-epoxy} = 0.034 \text{ in.}^3 * (16.4 \times 10^{-9} \text{ m}^3 / \text{in.}^3) * 1200 \text{ kg/m}^3 * 1750 \text{ J/(kg}^\circ\text{C)} * = 0.0012 \text{ J}^\circ\text{C} \quad \text{Equation 16}$$

$$C_{IC-heat\ spreader} = 0.005 \text{ in.}^3 * (16.4 \times 10^{-9} \text{ m}^3 / \text{in.}^3) * 8960 \text{ kg/m}^3 * 385 \text{ J/(kg}^\circ\text{C)} * = 0.0003 \text{ J}^\circ\text{C} \quad \text{Equation 17}$$

The total thermal capacitance is 0.0117 J°C.

Calculating with this thermal capacitance and the thermal resistance from above gives us a thermal time constant of:

$$\tau_{TH} = (11.1 \text{ }^\circ\text{C (sec / J)} * 0.0117 \text{ J / }^\circ\text{C)} = 0.13 \text{ seconds} \quad \text{Equation 18}$$

This means that we can leave the amplifier on at full output power for 1.5 time constants:

$$1.5 * 0.13 = 0.20 \text{ seconds} \quad \text{Equation 19}$$

These on and off ratios are comfortably within the ranges of the dynamic elements of most music. (The EIA Specification for audio amplifiers, RS-490, Section 3.2, Dynamic Headroom, requires only a 20 ms burst of a 1 kHz sine wave at the clipping level, once each ½ second.) Almost all music sources produce considerably less than peak power levels. Most music runs -3 to -16dB below peak most of the time. To get a "feel" for the thermal effects, we drove both channels of the EB-2060S Demo Amplifier board with a regulated 28 volt supply into heavy compression using 8Ω speakers. With heavily compressed Rock music the case temperature of the DDX-2060 Power IC ran between 50°C and 60°C. With Mega-Bass sound sources the case temperature rose to between 70°C and 90°C, which is comfortably below the device operating limits.

## 5. Other Thermal Considerations

Up to this point we have been discussing cooling in free air. Mounting the board in a TENV (totally enclosed non-ventilated) environment will produce elevated ambient temperatures within the enclosure. This increased ambient temperature must be accounted for in the final thermal design. With TENV enclosures, the entire **inside** of the case becomes a heatsink for absorbing all the power radiated by the PC board, internal heatsinks and other components into the enclosed air. The entire **outside** of the TENV case then becomes the heatsink for re-radiating that power to the environment. This process is usually not very efficient and can cause internal heating of the enclosure. In these cases, additional cooling may be required on the board.

An example of an inexpensive heatsink for use with the PowerSO package is AAVID's D<sup>3</sup>PAK heatsink, part #573400<sup>1</sup>, shown in Figure 5. This is a surface mount heatsink, available on tape and reel that can provide up to 2½ watts of auxiliary cooling to the PowerSO when mounted directly across the package in free air. Two heatsinks, when mounted on either side of the package, can provide up to 4 total watts of additional cooling. Test results of the EB-2060S Demo Board with these heatsinks are shown in Table 2.

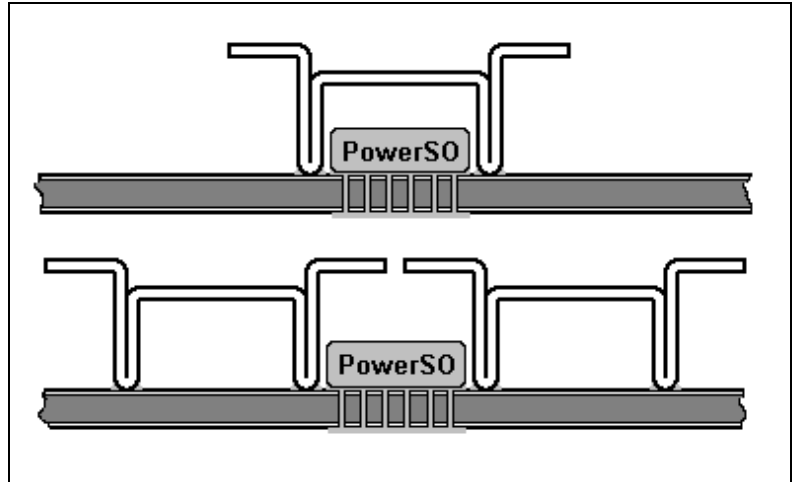

Figure 5. PowerSO With One or Two AAVID #573400 Heat Sinks.

Method	<u>RMS</u> Output Power
Two-ounce double-sided foil board with vias.	50 Watts
With Addition of One Heatsink	58 Watts
With Addition of Two Heatsinks	65 Watts

Table 2. Test Results of EB-2060S Output Power vs. Heatsink Method

It is recommended that rather than use TENV enclosures, openings in the enclosure should be made directly above and below heat producing internal components to allow air circulation. Remember to consider safety regulations when determining the size and location of the openings.

In the case of a speaker enclosure, where the addition of ventilation holes is not an option, the paths available to the outside air are through the case material, speaker cone and the bass port opening. Calculations should be made to ensure that proper airflow is provided through the enclosure to properly cool all internal components.

<sup>1</sup> The author wishes to thank the folks at Aavid Thermalloy for providing samples of the #573400 heatsink. Information on this heatsink can be found at their web site: <http://www.aavidthermalloy.com/datashts/DPak/index.html>

## **6. Conclusions**

With the very high power efficiency that DDX<sup>®</sup> amplification provides, the use of a PowerSO package mounted with just the cooling provided by two 5 square inch layers of the two-ounce copper PC board, (connected together with proper vias), can yield moderate to high output power levels with no auxiliary cooling required. Mounting within certain enclosed areas may require additional cooling methods.

**Each product designer retains final responsibility for his or her design...**

**Appendix A. Properties of Certain Materials**

<b>Material</b>	<b>Density (kg/m<sup>3</sup>)</b>	<b>Specific Heat (J/kg-°C)</b>	<b>Thermal Conductivity (W/m-°C)</b>
Air	1.2	1004	0.02563
Aluminum	2,710	875	204
Copper	8,960	385	386
FR-4 epoxy board	1,200	1750	3
Gold	19,320	126	310
Silver	10,500	235	429
Solder (tin/lead)	9,290	167	48
Steel	7,850	434	60.5
Thermal grease	2,400	2093	0.87
Water	998.2	4186	0.61

*Table 3. Properties of Certain Materials*

## Appendix B. What About Using Thinner Copper Foils?

This paper has been based on a two-ounce per square foot, two-sided, copper PC board. It stands to reason that thicker copper layers such as three-ounce or four-ounce per square foot will have an even better thermal performance. A three or four ounce two-sided copper board will have a lower spreading resistance and thus should be able to dissipate enough of the IC's internal power at room temperature to allow the full 70 watts of output power continuously as long as the surface area is made sufficiently large on both sides of the board.

But what if we want to save money by using **one-ounce copper board** instead. Here we run into some difficult issues. First, with only one-half the available copper thickness (compared to a two-ounce copper board) the spreading resistance is doubled, thereby decreasing the effective heat sink cooling area to about 50% of the original effective area. Remember also that the layer thickness is determined by weight per square foot, not copper sheet thickness. As a result of some PC board's manufacturing processes, the unevenness in the copper foil, due to the rippled surface of the epoxy board beneath it, can actually result in thermal voids. Consult your PC board material vendor regarding its manufacturing methods.

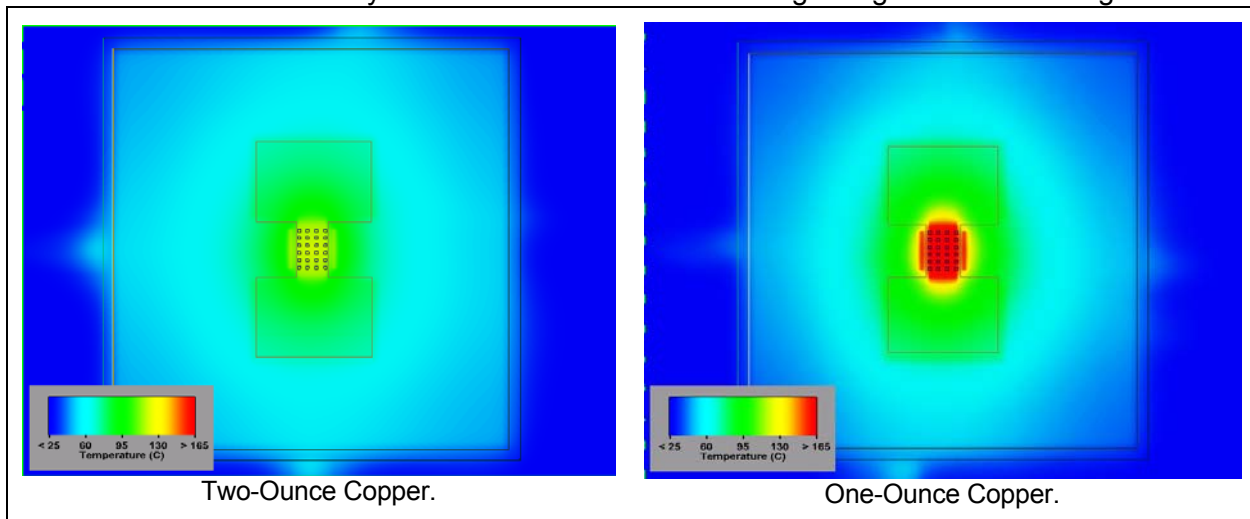

*Figure 6. Thermal gradients of a PowerSO on a 5 in. x 5 in. two-sided board vs. copper foil thickness.*

Figure B1 shows the thermal gradient across 5 in. x 5 in. two-ounce and one-ounce PC boards when 8 watts is dissipated in each PowerSO. Simulations were taken at the topmost surface of the board just below the IC. Note that the two-ounce board's maximum temperature is 121°C, which is within the allowable temperature limit (130°C) for FR-4 material. The one-ounce board's temperature is almost 164°C, which exceeds both the maximum junction temperature (150°C) and the board's mechanical limits (140°C) for FR-4 material. Figure B2 shows the foil pattern layout for the top of the board as used in the model. The light areas are copper with the dark areas being uncoated FR4 material. The bottom side was modeled as a solid copper sheet connected through to the top with the recommended vias. The results of thermal modeling, provided by **Flomerics, Inc.**, using

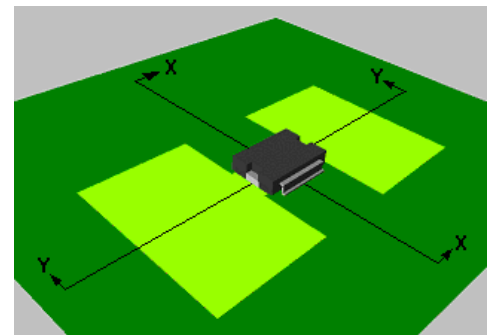

*Figure 7. Top Foil Pattern for Model.*

their **FLOTHERM™<sup>2</sup>** thermal modeling software, corresponds very closely with actual measurements taken during operation. The thermal modeling showed that the PowerSO on the two-ounce board stayed within design limits while the PowerSO on the one-ounce board overheated. Using a one-ounce copper board as a heatsink requires either lowering the output power or the use of an auxiliary heat sink.

Figure B3 shows the thermal gradients in the Y-Y and X-X directions as defined in Figure B2. Notice the slight bump on the topside of the X-X curves at approximately 0.25 inches. This is due to heat flow out of the PowerSO pins. The bump on the left side at 1.25 inches is where the top-side foil ends. We have also included modeling for a 5 in x 5 in sheet of 1/16-inch thick aluminum for comparison purposes.

As you can see, the heat rise is concentrated tightly around the IC for both foil weights but the two-ounce copper board is spreading the heat better than the one-ounce board and thus running cooler. The Aluminum sheet however has much lower spreading resistance than either foil and so runs at nearly the same temperature across its entire surface. (It would require two layers of 12 ounce copper foil on a PC board to match the cooling curve of the 1/16" aluminum sheet.)

What this all means is that either the design power will have to be reduced to allow for the poorer cooling of the thinner foils or additional heatsinks will have to be added. The AAVID heatsink discussed in the main part of this paper can help but, due to the one-ounce copper foil's higher spreading resistance between the PowerSO and the heatsink, will perform at a lower power dissipation.

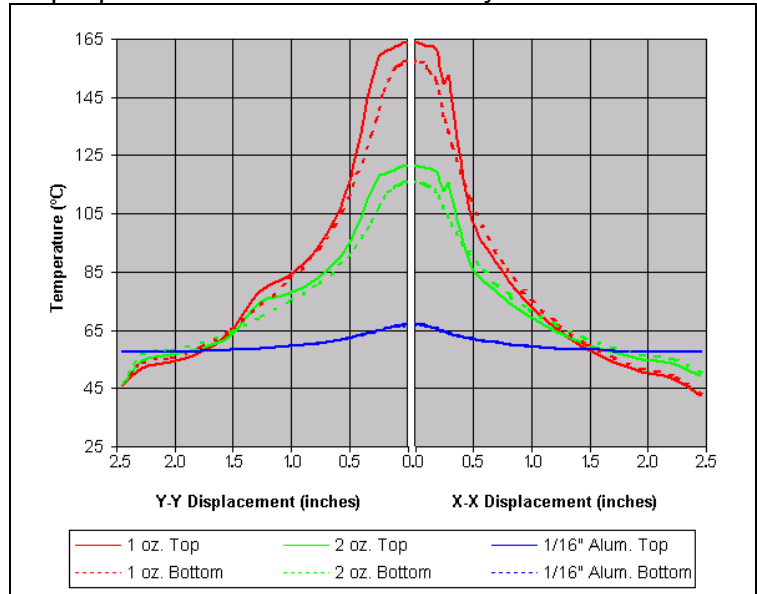

**Figure 8. Thermal Gradients of Some 5 in. x 5 in. Materials**

<sup>2</sup> The author wishes to thank **Flomerics, Inc.**, for the use of their **FLOTHERM™** Thermal Modeling Software in preparing the thermal models and analyses used in this paper. For inquiries about this product, please contact them at:

Flomerics, Inc.  
 257 Turnpike Road, Suite 100  
 Southborough, MA 01772  
 Tel: 508-357-2012  
 Fax: 508-357-2013  
<http://www.flomerics.com> or <http://www.flotherm.com>

**Appendix C. Effects of Device Positioning on the Board**

**Cooling loss due to device position on the board.**

When you move the PowerSO from the center (Figure B2) to one side of the board (Figure C1-a) the temperature rise will nearly double due to the effectively smaller cooling area. Moving it to one corner of the board (Figure C1-b) will make the temperature rise almost double once again to more than 3.5 times the original temperature rise.

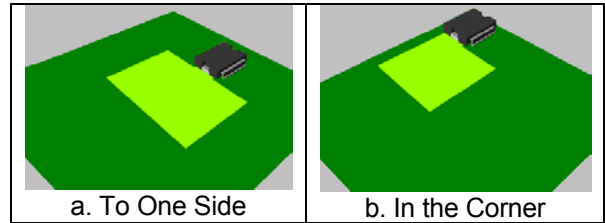

*Figure 9. Positioning the PowerSO*

**Cooling loss due to device proximity.**

Figure C2 shows the results of placing two PowerSOs one inch apart, center-to-center, on a two-ounce double-sided copper board. As mentioned at the beginning of this paper, superposition principles apply. That means that we can just add the individual thermal heat flows from each PowerSO IC together at any point within the copper foil to arrive at the total temperature rise at that point. The “effective” 2.5 inches cooling diameter suggests that you not mount two devices within 2.5 inches of each other if you expect to get optimal cooling. The overall effect of mounting power devices too close together is worse than if you had just cut each one’s heatsink off at the dividing line between them.

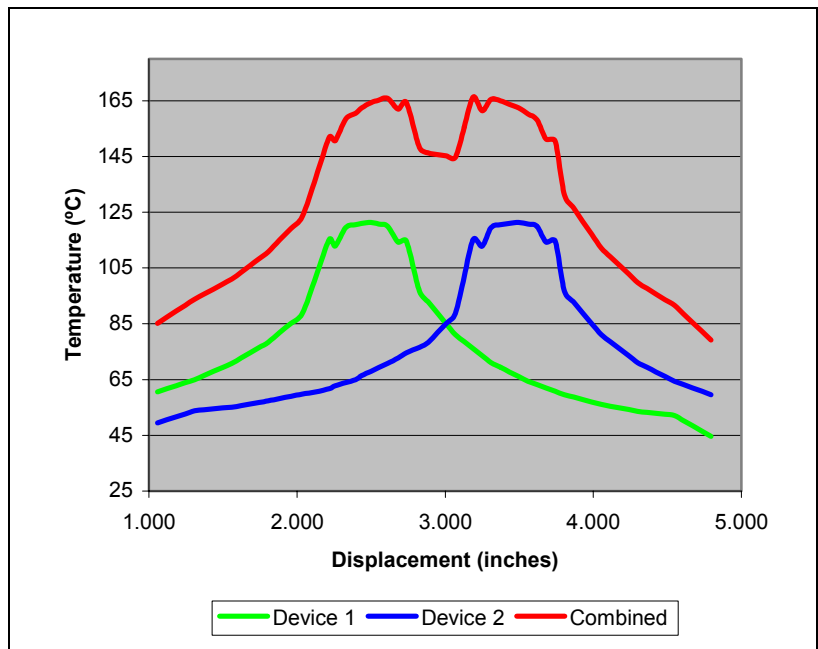

*Figure 10. Heat Rise Of Two PowerSOs Placed One Inch Apart*